

Planta de producción de e-Metanol a partir de hidrógeno verde

ANEXO I - Ficha técnica aerogenerador



Socio estratégico: SEG Ingeniería.





Página intencionalmente en blanco
para impresión en doble faz.

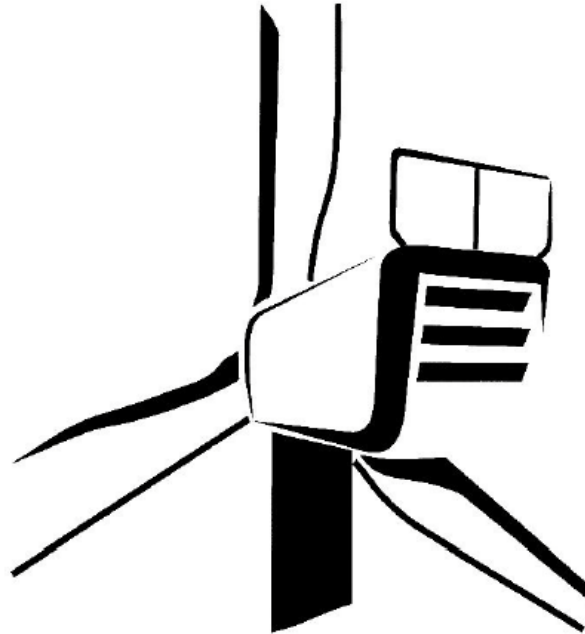

	<p align="center">GENERAL DOCUMENTATION</p>	Doc.: 2000627EN
		Rev.: 12
<p align="center">TECHNICAL DESCRIPTION DELTA4000 - N163/5.X, N163/5.X ESH</p>		Page: 1 / 22



- Translation of the original document (E0004923356, rev. 13) -
This is a translation from German.
In case of doubt, the German text shall prevail.

Language: EN – English
Department: Engineering/ CPS / Processes & Documents

<p>Author</p>  <p align="center">11-10-2023</p>	<p>Reviewer</p>  <p align="center">11-10-2023</p>	<p>Approver</p>  <p align="center">12-10-2023</p>
--	--	--

 	GENERAL DOCUMENTATION	Doc.: 2000627EN
		Rev.: 12
TECHNICAL DESCRIPTION		Page: 2 / 22

This document, including any presentation of its contents in whole or in parts, is the intellectual property of Nordex Energy SE & Co. KG. The information contained in this document is intended exclusively for Nordex employees and employees of trusted partners and subcontractors of Nordex Energy SE & Co. KG., Nordex SE and their affiliated companies as defined in Section 15ff. of the German Stock Corporation Act (AktG) and must never (not even in extracts) be disclosed to third parties.

All rights reserved.

© 2023 Nordex Energy SE & Co. KG., Hamburg, Germany

This document contains information which property rights belong to the Nordex Group and cannot be copied, used, published or disclosed in any form to third parties without the prior written consent of authorized personnel within the Nordex Group. All information contained herein must be kept secret and be used just for the exclusive benefit of the Nordex Group.

Address of manufacturer as per Machinery Directive

Nordex Energy SE & Co. KG.

Langenhorner Chaussee 600

22419 Hamburg

Germany

Tel.: +49 (0)40 300 30 -1000

Fax: +49 (0)40 300 30 -1101

info@nordex-online.com

<http://www.nordex-online.com>

Validity

Turbine generation	Product series	Product
Delta	Delta4000	N163/5.X N163/5.X ESH

1.	Structure	5
1.1	Tower	5
1.2	Rotor	6
1.3	Nacelle	6
1.4	Auxiliary systems	8
1.4.1	Automatic lubrication system	8
1.4.2	Heaters.....	8
1.4.3	E-chain hoist and crossbeam.....	8
1.4.4	Cooling system	8
2.	Control and electrical system	9
2.1	Safety systems.....	10
2.2	Lightning/surge protection, electromagnetic compatibility (EMC)	10
2.3	Medium-voltage system.....	10
2.4	Low-voltage grid types	11
2.5	Auxiliary power of the wind turbine	12
3.	Options	13
4.	Technical data	14
4.1	Technical design	14
4.2	Towers	15
4.3	Rotor and rotor blades.....	16
4.4	Nacelle	16
4.4.1	Rotor shaft	16
4.4.2	Brake and gearbox	17
4.4.3	E-chain hoist and crossbeam.....	17
4.5	Electrical system	17
4.5.1	Transformer	18
4.5.2	Medium-voltage switchgear	19
4.5.3	Generator	20
4.6	Cooling system.....	20
4.7	Pitch system	21
4.8	Yaw system	21
4.9	Corrosion protection.....	21
4.10	Automation systems	21

1. Structure

The Nordex N163/5.x, N163/5.x ESH wind turbine is a speed variable wind turbine with a rotor diameter of 163 m and a rated power of up to 5900 kW, which can be adjusted depending on the location. The wind turbine is designed for class S in accordance with IEC 61400-1 or wind zone S in accordance with DIBt 2012 and is available in 50 Hz and 60 Hz variants.

The Nordex N163/5.x, N163/5.x ESH wind turbine consists of the following main components:

- Rotor with rotor hub, three rotor blades and the pitch system
- Nacelle with rotor shaft and bearing, gear, generator, Yaw system, medium voltage transformer and converter
- Steel tube tower, hybrid tower or concrete tower with medium-voltage switchgear

1.1 Tower

The N163/5.x, N163/5.x ESH wind turbine can be built on a tubular steel tower, a hybrid tower or a concrete tower. The tubular steel tower consists of several conical or cylindrical sections. This tower is bolted to the anchor cage embedded in the foundation. The bottom part of the hybrid tower consists of a concrete tower and the top part of a tubular steel tower with three sections. The concrete tower consists completely of concrete elements.

A climbing assistance, e. g a service lift or a climb assist, the vertical ladder with fall arrest system as well as resting and working platforms inside the tower allow for a weather-protected ascent to the nacelle.

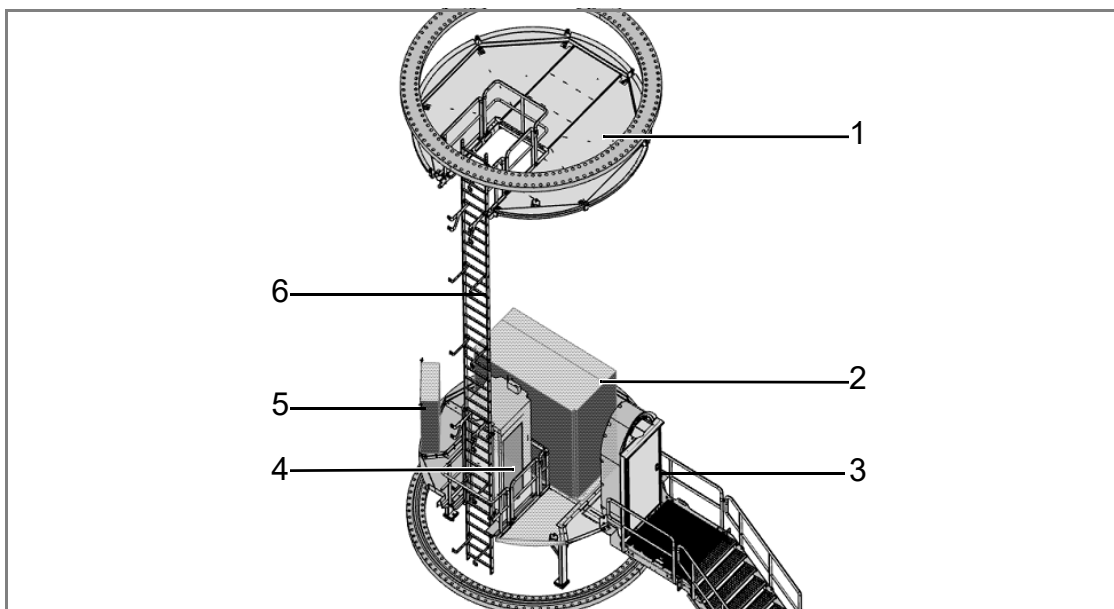

Fig. 1: Overview of the installations in the Bottom section of the tubular steel tower with a service lift (figure different in the case of climb assist)

- | | |
|-------------------|----------------------|
| 1 Flange platform | 4 Tower service lift |
| 2 MV switchgear | 5 Control cabinet |
| 3 Tower access | 6 Ladder path |

The foundation structure of all towers depends on the soil conditions at the intended location.

1.2 Rotor

The rotor consists of the rotor hub with three slewing bearings, the pitch system for blade adjustment and three rotor blades.

The **rotor hub** consists of a base element with support system and spinner. The base element consists of a stiff cast structure, on which the pitch bearings and the rotor blades are assembled. The rotor hub is covered with the spinner which enables the direct access from the nacelle into the rotor hub.

The **rotor blades** are made from high quality fiber glass- and carbon-fiber reinforced plastic. The rotor blade is tested statically and dynamically in accordance with the guidelines IEC 61400-23 and DNVGL-ST-0376.

The **pitch system** serves to adjust the pitch angle of the rotor blades set by the control system. For each individual rotor blade the pitch system comprises an electromechanical drive with rotary current motor, planetary gear and drive pinion, as well as a control unit with frequency converter and emergency power supply. Power supply and signal transfer are realized through a slip ring in the nacelle.

1.3 Nacelle

The nacelle contains essential mechanical and electric components of the wind turbine.

The **rotor shaft** transmits the rotary motion of the rotor to the gearbox and is mounted in the **rotor bearing** in the nacelle. A rotor lock is integrated in the rotor bearing housing, with which the rotor can be reliably locked in place mechanically.

With the mechanical **rotor brake** the rotor lock is engaged during maintenance work. For this, a sufficient oil pressure is generated by the hydraulic pump.

The **gearbox** increases the rotor speed until it reaches the speed required for the generator. The bearings and gearings are continuously lubricated with oil. A combination filter element with coarse, fine and ultrafine filter retains solid particles. The control system monitors the contamination of the filter element. The gear oil used for lubrication also cools the gearbox. The temperatures of the gearbox bearings and the oil are continuously monitored. If the optimum operating temperature is not yet reached, a thermal bypass directs the gear oil directly back to the gearbox. Only when the gear oil temperature reaches a predetermined value is the transmission oil cooled by an oil / water cooler, which is located directly on the gearbox. As a result, the gear oil temperature is kept in a narrow temperature range during operation.

The **coupling** acts as force-transmitting connection between the gearbox and the generator.

The **generator** is a 6-pole doubly-fed induction machine. The generator has a built-on air-water heat exchanger and is connected to the cooling circuit.

The **converter** connects the electrical grid to the generator which means the generator can be operated with variable rotational speeds.

The **transformer** converts the low voltage of the generator-converter system into medium voltage of the wind farm grid. The transformer is cooled by the connection to the cooling circuit.

In the **switch cabinet**, all electrical components required for the control and supply of the turbine are located.

The cooling water is re-cooled by a **passive cooler** on the nacelle roof.

The **yaw drives** optimally rotate the nacelle into the wind. The yaw drives are located on the machine frame in the nacelle. A yaw drive consists of an electric motor, multi-stage planetary gear, and a drive pinion. The drive pinions mesh with the external gearing of the yaw bearing. In the aligned position the nacelle is held with the yaw drives.

All nacelle assemblies are protected against wind and weather conditions by means of a **nacelle cover**.



Abb. 2: Schematic diagram of the nacelle

- | | | | |
|---|----------------|----|-------------|
| 1 | Passive cooler | 7 | Yaw drives |
| 2 | Switch cabinet | 8 | Rotor brake |
| 3 | Gearbox | 9 | Coupling |
| 4 | Rotor shaft | 10 | Transformer |
| 5 | Nacelle cover | 11 | Generator |
| 6 | Rotor bearing | 12 | Converter |

1.4 Auxiliary systems

1.4.1 Automatic lubrication system

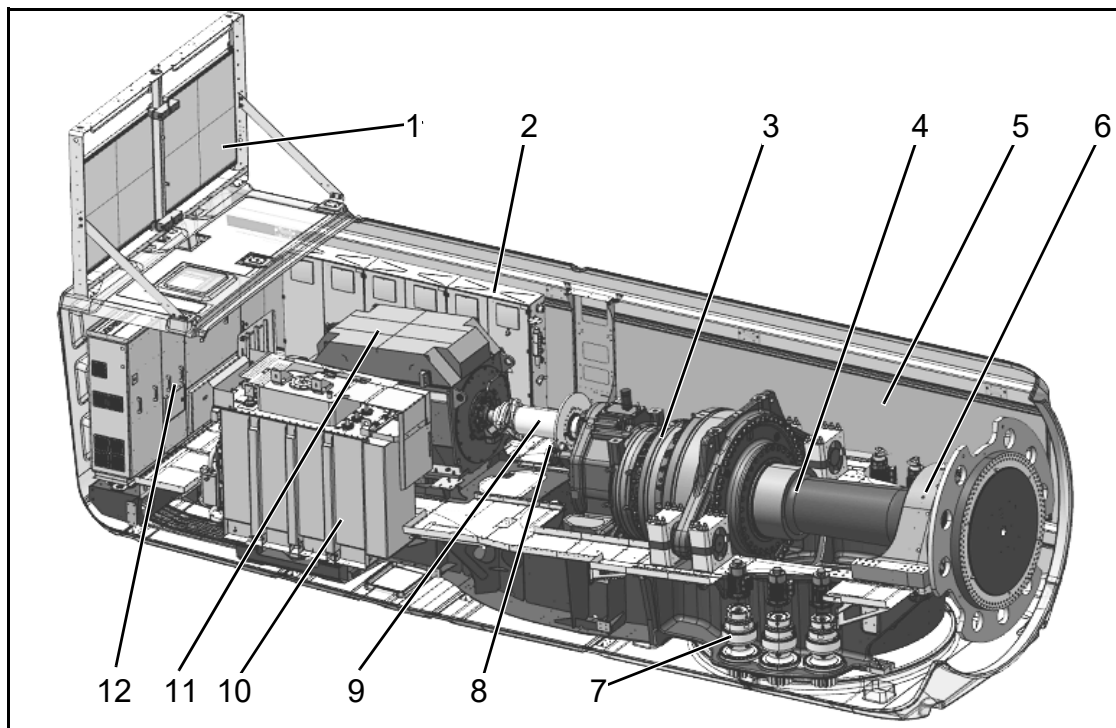
Generator bearing, gearing of the pitch bearings, rotor bearing and gearing of the yaw bearing are each equipped with an **automatic lubrication system**.

1.4.2 Heaters

Gearbox, generator, cooling circuit and all relevant switch cabinets are equipped with **heaters**.

1.4.3 E-chain hoist and crossbeam

An electric **chain hoist** is installed in the nacelle which is used for lifting tools, components and other work materials from the ground into the nacelle.

A crossbeam including a sliding trolley is prepared for the use of a manual chain hoist to move the materials within the nacelle.

1.4.4 Cooling system

Two separate cooling circuits ensure cooling of the large components. Converter and gearbox are cooled in one cooling circuit and generator and transformer in the other.

Both cooling circuits are connected to passive coolers on the nacelle roof, in which the water is re-cooled.



Abb. 3: Schematic representation of the cooling circuit

2. Control and electrical system

The WT operates automatically. A programmable logic controller (PLC) continuously monitors the operating parameters using various sensors, compares the actual values with the corresponding setpoints and issues the required control signals to the WT components. The operating parameters are specified by Nordex and are adapted to the individual location. The controller is located in a switch cabinet in the tower base.

When there is no wind the WT remains in idle mode. Only various auxiliary systems are operational or activated as required: e.g., heaters, gear lubrication or PLC, which monitors the data from the wind measuring system. All other systems are switched off and do not use any energy. The rotor idles. When the cut-in wind speed is reached, the WT changes to the "ready for operation" condition. Now all systems are tested, the nacelle turns into the wind and the rotor blades turn into the wind. When a certain speed is reached, the generator is connected to the grid and the WT produces electrical energy.

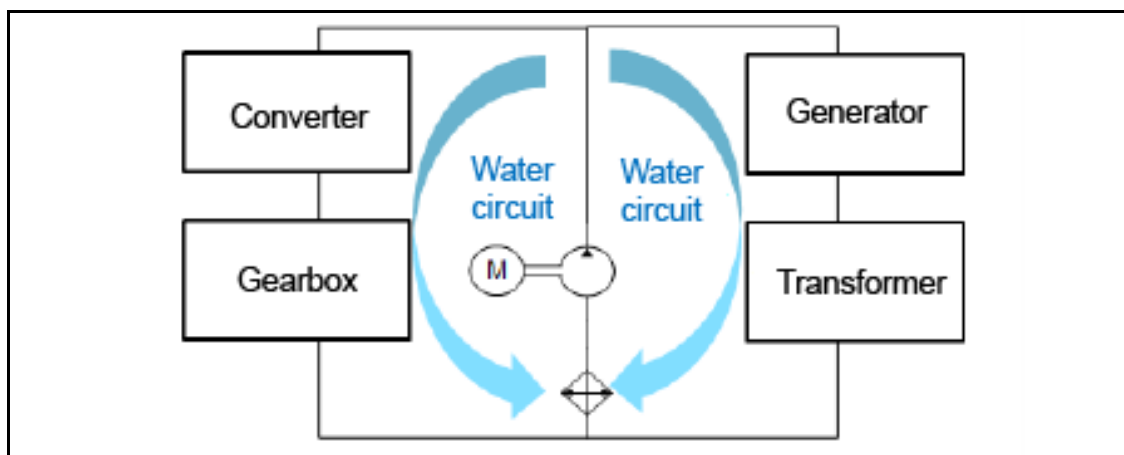
At low wind speeds the WT operates at part load. The rotor blade remain turned into wind to the maximum extent. The power produced by the WT depends on the wind speed.

When the nominal wind speed is reached, the WT switches over to the nominal load range. If the wind speed continues to increase, the speed control changes the rotor blade angle so that the rotor speed and thus the power output of the WT remain constant.

The yaw system ensures that the nacelle is always optimally aligned to the wind. To do this two separate wind measuring systems on the nacelle measure the wind direction. Only one wind measuring system is used for the control system, while the second system monitors the first and takes over in case the first system fails. If the wind direction measured deviates too much from the nacelle alignment, the nacelle is yawed into the wind.

The wind energy absorbed from the rotor is converted into electrical energy using a doubly-fed induction machine with slip ring rotor. Its stator is connected directly, and the rotor is connected via a specially controlled frequency converter, to the MV transformer which connects the turbine to the grid. As a result, only a part of the power needs to be routed via the converter, permitting low electrical system losses.

2.1 Safety systems

Nordex wind turbines are equipped with technical equipment and devices that protect people and systems and ensure permanent operation. The entire turbine is designed in accordance with the Machinery Directive 2006/42/EC and certified as per IEC 61400.

Safety-related parameters in the system control are monitored continuously. Here, the sensor data of the safe sensors are transmitted via a safe bus system to the safe controller for evaluation. If specified parameters are exceeded, the system is stopped via safe actuators and set to a safe state.

Depending on the cut-out cause, different brake programs are triggered. In event of external causes, such as excessive wind speeds or below operating temperatures, the wind turbine is gently braked by means of rotor blade adjustment.

Other safety functions are used to stop drives safely for maintenance work.

2.2 Lightning/surge protection, electromagnetic compatibility (EMC)

The lightning/surge protection of the wind turbine is based on the EMC-compliant lightning protection zone concept, which comprises the implementation of internal and external lightning/surge protection measures under consideration of the standard IEC 61400-24. The wind turbine is designed according to lightning protection level I.

The wind turbine with the electrical equipment, consumers, the measurement, control, protection, information and telecommunication technology meets the EMC requirements according to IEC 61400-1.

2.3 Medium-voltage system

The medium voltage components are used to connect a WT to the wind farm medium-voltage grid or the local grid operator. The tower base contains the **MV switchgear**. It consists of a transformer field with circuit breakers and at least one ring cable field as default and up to three ring cable fields as an option (dependent on the wind farm configuration). The transformer panel consists of a vacuum circuit breaker and the disconnecter with ground switch. The ring cable panel consist of a switch disconnecter with a ground switch. The entire MV switchgear is assembled on a support/adaptor frame.

Further characteristics of the MV switchgear:

- Routine tests of each switchgear in compliance with IEC 62271-200
- Type tested, SF6 insulation
- Internal switchgear for self-contained electrical systems (min. IP2X)
- SF-6 tank: metal-clad, metal-enclosed (min. IP65), independent of environmental influences
- Switch positions shown "On - Off - Grounded"
- Test terminal strip for secondary test
- Low-maintenance in accordance with class E2 (IEC 62271-100)

In case of technical availability Nordex as an alternative to traditional SF6 insulated switchgear can also supply SF6-free switchgear. This option is to be agreed upon with Nordex in advance.

The system protection of the MV switchgear is achieved by the following items:

- Improved personal safety and system protection in case of arcing by type testing in compliance with IEC 62271-200.
- Protection device supplied with converter current and stabilized for inrush current as DMT relay (independent maximum current protection).
- Actuating openings for switchgear are interlocked to preclude operation of more than one simultaneously, and can be locked as an option.
- Corrosion protection of the switchgear cells through hot-dip galvanization and painted surfaces.
- Pressure relief by pressure absorber duct in case of arcing. Alternatively, for the USA, an arc suppressor can be installed in the tank and in the cable connection compartment.

Transformer and **converter** are located in the nacelle. The transformer has been specified in accordance with IEC 60076-16.

The steel components at the transformer are dimensioned for corrosion protection class C3 (H).

Additional protection measures:

- Grounded tank (Ester transformer)
- Overtemperature protection with temperature sensor and relay
- Hermetic protection (leakage) and overpressure protection for ester transformer

2.4 Low-voltage grid types

The **750 V low voltage grid** is the primary wind turbine low voltage energy system. It is insulated from the ground as an IT grid and three phase AC network. The elements of the electrical operating and measuring devices of this network are grounded directly or via separate protective equipotential bonding cables. A central insulation monitor has been installed as another protective measure for personal and turbine safety in the 750-V-IT system.

The **400 V / 230 V low voltage grid** is the auxiliary wind turbine low voltage system. It has its neutral point grounded directly in the supplying grid transformers as a TN system and three-phase system. The equipment grounding conductor PE and the neutral conductor are available separately. The bodies of electrical equipment and consumers, including the additional protective equipotential bonding, are connected directly, through protective earthing conductor connections, straight to the neutral points of the supply grid transformers.

2.5 Auxiliary power of the wind turbine

The auxiliary low voltage required by the wind turbine in stand-by mode and feed-in mode is requested by the following consumers:

- System control including main converter control
- 400 V/230 V auxiliary power of the main converter
- 230 V AC UPS supply including 24 V DC supply
- Yaw system
- Pitch system
- Auxiliary drives such as pumps, fans and lubrication units
- Heating and lighting
- Auxiliary systems such as service lift, obstacle lights

Long-term measurements show that the average annual base load of the low-voltage auxiliary power plant in WT feed-in operation is approx. 15 kW in the average 10-min average value and the maximum 10-min average value can reach up to 25 kW/32kVA. These values are already included in the power curves.

For locations with an average annual wind speed of 6.5 m/s approx. 10 MWh auxiliary consumption arise, however, this value is greatly dependent on location.

Auxiliary consumption is defined as the energy consumption of the WT from the grid for a period during which the WT does not supply current to the grid.

3. Options

Various options are available upon request as additional equipment for Nordex wind turbines.

The option of optional equipment must be coordinated with Nordex in advance.

4. Technical data

4.1 Technical design

Technical design	
Survival temperature	-40 °C to +50 °C
Operating temperature range of the Normal Climate Version	-20 °C to +40 °C ¹
Operating temperature range of the Cold Climate Version	-30 °C to +40 °C ¹
Stop	Standard: -20 °C, restart at -18 °C CCV: -30 °C, restart at -28 °C
Max. height above MSL	2000 m ¹
Certificate	In accordance with IEC 61400-22 and DIBt 2012
Type	3-blade rotor with horizontal axis Upwind turbine
Output control	Active single blade adjustment
Rated power	up to 5900 kW ¹
Rated power starting at wind speeds of (at air density of 1.225 kg/m ³)	approx. 12.5 m/s
Operating speed range of the rotor	6.0 min ⁻¹ to 11.8 min ⁻¹
Nominal speed	approx. 10.4 min ⁻¹
Cut-in wind speed	3 m/s
Cut-out wind speed	26 m/s ²
Cut-back-in wind speed	25.5 m/s ²
Calculated service life	≥20 years

¹ Rated power is achieved depending on the power factor and the installation altitude up to defined temperature ranges.

² Depending on the project, the cut-out wind speed can be decreased to safeguard the structural stability.

4.2 Towers

N163/5.X

Towers	TS98-01	TS100-00	TS108-01	TS108-05	TS118-00	TS125-06	TS148-00
Hub height*	98.5 m	102.0 m	107.5 m	108.0 m	118.0 m	125.0 m	148.0 m
Tower type	Tubular steel tower						
Wind class	IEC S	IEC S	IEC S	IEC S	DIBt S/ IEC S	IEC S	IEC S
Number of tower sections	4	4	4	5	5	6	6
Surface finish	Color system coating						

Towers	TS159-00	TC120N-01	TCS164B	TCS168N
Hub height*	158.5 m	120.0 m	164.0 m	168-0 m
Tower type		Concrete tower	Hybrid tower	Hybrid tower
Wind class	IEC S	IEC S	DIBt S/ IEC S	IEC S
Number of tower sections	7	Concrete tower	3 steel sections 1 concrete part	3 steel sections 1 concrete part
Surface finish	Color system coating	Fair-faced concrete	**	**

* Includes foundation height above ground level

** Steel section: Color system coating; Concrete part: Fair-faced concrete

N163/5.X ESH (Extended Suitability Hub)

Towers	TC120N-01
Hub height*	120.0 m
Tower type	Concrete tower
Wind class	IEC S
Number of tower sections	Concrete tower
Surface finish	Fair-faced concrete

* Includes foundation height above ground level

4.3 Rotor and rotor blades

Rotor	
Rotor diameter	163.0 m
Swept area	20867 m ²
Rated power/area	273 W/m ²
Rotor shaft inclination angle	5°
Blade cone angle	N163/5.X: 4.0° N163/5.X ESH: 5.5°

Rotor blade	
Material	fiber glass and carbon-fiber reinforced plastic
Total length	79.7 m

Rotor hub	
Material of the rotor hub base body	Casting
Material spinner	glass-fiber reinforced plastic

4.4 Nacelle

Nacelle	
Support structure	welded steel structure
Cladding	glass-fiber reinforced plastic
Machine frame	Casting
Generator frame	welded steel construction

4.4.1 Rotor shaft

Rotor shaft/rotor bearing	
Type	Forged hollow shaft
Material	42CrMo4 or 34CrNiMo6
Bearing type	Spherical roller bearing
Lubrication	Regularly using lubricating grease

4.4.2 Brake and gearbox

Mechanical brake	
Type	Actively actuated disk brake
Location	On the high-speed shaft
Number of brake calipers	1
Brake pad material	Organic pad material

Gearbox	
Type	Multi-stage planetary gear + spur gear stage
Gear ratio	50 Hz: $i = 121.5$ 60 Hz: $i = 145.8$
Lubrication	Forced-feed lubrication
Oil quantity including cooling circuit	Max. 650 l
Oil type	VG 320
Max. oil temperature	Approx. 77 °C
Oil change	Change, if required

4.4.3 E-chain hoist and crossbeam

Electrical chain hoist and lifting beam	
Electrical chain hoist max load	Min. 850 kg
Crossbeam max load	Sliding trolley to accommodate a manual chain hoist 1000 kg

4.5 Electrical system

Electrical system	
Rated power P_{nG}	up to 5900 kW*
Nominal voltage	3 x AC 750 V \pm 10 % (specific to grid code)
Nominal current during full reactive current feed-in I_{nG} at S_{nG}	4889 A
Nominal apparent power S_{nG} at P_{nG}	6351 kVA
Power factor at P_{nG}	1.00 as default setting 0.929 underexcited (inductive) up to 0.929 overexcited (capacitive) possible
Frequency	50 and 60 Hz

* All data are maximum values. The values may deviate depending on the rated voltage, rated apparent power and WT active power.

4.5.1 Transformer

Transformer*	50 Hz	60 Hz
Total weight	approx. 9 t	
Insulation medium	Ester	
Rated voltage OV, U_r	750 V	
Maximum rated voltage OS, dependent on MV grid, U_r	20 kV / 30 kV / 34 kV	
Taps, overvoltage side	20 kV and 30 kV: + 4 x 2.5 % 34 kV: + 4 x 0.5 kV	
Grid voltage OS	20; 20.5; 21; 21.5; 22 kV 30; 30.75; 31.5; 32.25; 33 kV 34; 34.5; 35; 35.5; 36 kV	
Rated frequency, f_r	50 Hz	60 Hz
Vector group	Dy5	
Installation altitude (above MSL)	Up to 2000 m	
Rated apparent power, S_r	6350 kVA	
Impedance voltage, U_z	8 to 9 % \pm 10 % tolerance	
Minimum peak efficiency index, η , (EU) 2019/1783, 548/2014	99.571 %	-
Inrush current	$\leq 5.5 \times I_N$ (peak value)	
Power loss ¹		
No-load losses	2900 W	4000 W
Short circuit losses	70000 W	71000 W

* The values are, if not specified otherwise, maximum values. The values may deviate depending on the rated voltage, rated apparent power and WT active power.

¹ Guide values.

4.5.2 Medium-voltage switchgear

Medium-voltage switchgear	
Rated voltage (depending on MV network)	24; 36; 38 or 40.5 kV
Rated current	50 Hz: 630 A 60 Hz: 600 A
Rated short-circuit duration	1 s
Rated short circuit current	24 kV: 16 kA (20 kA optional) 36 / 40.5 kV: 20 kA (25 kA optional)
Minimum/maximum ambient temperature during operation	NCV: -25 °C to +40 °C
	CCV: -30 °C to +40 °C
Connection type	External cone type C according to EN 50181 For USA: External cone type E according to IEEE 386
Circuit breaker	
Number of switching cycles with rated current	E2
Number of switching cycles with short-circuit breaking current	E2
Number of mechanical switching cycles	M1
Switching of capacitive currents	Min. C1 - low
Switch disconnector	
Number of switching cycles with rated current	E3
Number of switching cycles with short-circuit breaking current	E3
Number of mechanical switching cycles	M1
Disconnecter	
Number of mechanical switching cycles	M0
Ground switch	
Switching number with rated short-circuit inrush current	E2
Number of mechanical switching cycles	≥1000

4.5.3 Generator

Generator	
Type	6-pole doubly-fed induction machine
Degree of protection	IP 54 (slip ring box IP 23)
Nominal voltage	750 V
Frequency	50 and 60 Hz
Speed range	50 Hz: 650 to 1500 min ⁻¹ 60 Hz: 780 to 1800 min ⁻¹
Poles	6
Weight	approx. 12.5 t

4.6 Cooling system

Cooling system	
Gearbox	
Type	Oil circuit with oil/water heat exchanger and thermal bypass
Filters	Coarse filter 50 µm / fine filter 10 µm / ultrafine filter <5 µm
Generator	
Type	Water circuit with water/air heat exchanger and thermal bypass
Coolant	Water/glycol-based coolant
Converter	
Type	Water circuit with water/air heat exchanger and thermal bypass
Coolant	Water/glycol-based coolant
Transformer	
Coolant	Water/glycol-based coolant
Cooling circuit	Ester circuit with ester/water heat exchanger

4.7 Pitch system

Pitch system	
Pitch bearing	Double-row four-point contact bearing
Gearing/raceway lubrication	Regular lubrication with grease
Drive	Electric motors incl. spring-loaded brake and multi-stage planetary gear
Emergency power supply	Batteries

4.8 Yaw system

Yaw system	
Yaw bearing	Double-row four-point contact bearing
Gearing/raceway lubrication	Regular lubrication with grease
Drive	Electric motors incl. spring-loaded brake and four-stage planetary gear
Number of drives	5-6
Yaw speed	Approx. 0.4°/s

4.9 Corrosion protection

Corrosion protection*	Inside	Outside
Nacelle	C3	C4
Hub	C3	C4
Tower	C3	C4
Steel sections Concrete components	Color system coating Fair-faced concrete	Color system coating Fair-faced concrete

* Categories of corrosion protection according to ISO 12944-2

4.10 Automation systems

Automation system	
Field bus system	Profinet
Safe fieldbus system	Profisafe via Profinet
Turbine control	Profinet system control
Safety control	Integrated safety control
